

**40+ MILLION**  
**SAFE & HAPPY FAMILIES**  
WORLDWIDE



**LPG**  
**TORCHES**



# IGT PROPANE **WEED TORCH**

Propane torch kit for home and garden use

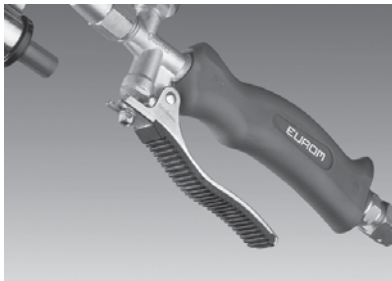



DENMARK

## Welcome to Integrated Gas Technologies

IGT is one of the Global leaders in the market for regulators and hoses for butane and propane cylinders.

IGT Headquartered in Denmark has two factories, NBSX located in Ningbo, China since 2004 and IGCT located in Hyderabad, India since 2016. IGT employs 245 people.

IGT uses the best raw materials such as zamac3, brass, steel and rubber for all components. In addition, we perform 100% quality control on both assembly and assembled finished products.

All LPG regulators come with a 5 year product warranty and \$ 5 million product liability insurance.

The factories have been audited and approved among others by international gas appliance companies and meet the high standards of these customer segments. Both factories are ISO9001 certified and in 2014 the NBSX factory was also BSCI certified ([www.bsci-int.org](http://www.bsci-int.org)), a social enterprise initiative aimed at ensuring compliance with the European Code of Conduct on Social Responsibility.

IGT aligns its production with the 17 United Nations Sustainable Development Goals to achieve a better and more sustainable future for all of us.



# IGT WORLD WIDE SALES NETWORK



IGT is a global supplier of domestic LPG Safety Device, with sales in over 125 countries.

IGT has a worldwide distribution sales network with own sales staff in Europe, United States, Russia-SNG countries, China and India.

See complete distributor and dealer list on [WWW.IGT-LPG.COM](http://WWW.IGT-LPG.COM)

- 📍 **Headquarters: Denmark**
- 📍 **Factory: Ningbo China, Hyderabad India**
- 📍 **Sales Office: Russia, USA, Kenya**

As a global gas regulator manufacturer IGT takes pride in product quality & durable products. We support UN Sustainable Development Goals with special focus on 3, 12 & 13. An extended product lifetime reduces environmental footprint.

IGT have reduced CO<sub>2</sub> emissions by 30% since 2004, 70% reduction target is achievable before 2025.

# CONTENT

04	GAS SAFETY	
05	BEST PRACTICE	
06	PROPERTIES OF GASES	
07	TORCH HANDLES	
10	SWIRVEL ADAPTOR	
11	SOLDERING	
14	EXTENSION TUBES	
16	MULTIPLE EXTENSIONS	
17	BURNER HEADS	
18	BURNERS	
19	BURNER HEADS	
20	TITANIUM TORCHES	
21	TORCH SETS	
22	ACCESSORIES	
23	USA GAS TORCHES	
24	HEATING SHRINK TORCH	
25	HIGH PRESSURE REGULATORS B100/B235/B300	

## LP gas and safety

- Leaking LP gas is a fire hazard
- LP gas is heavier than air
- LP gas uses air during combustion

There are primarily two things to think about to prevent accidents with LP gas

1. Avoid leakages
2. Ensure good ventilation

Leaking LP gas can ignite and cause a fire or in the worst case an explosion. The cylinder valve should always be closed when the cylinder is not in use. The cylinder should be stored upright and if possible, at ground level since LP gas is heavier than air and can therefore accumulate in cellars, manholes etc. Good ventilation is important when working indoors as the flame consumes air. Lack of oxygen causes incomplete combustion, which produces carbon monoxide instead of carbon dioxide. Carbon monoxide is a treacherous and deadly gas.

## LP gas and efficiency

- Permits very high power outputs. Energy is high.
- Fuel is easy to store and transport.

It is the property of changing from a gaseous form to a liquid form and vice versa that makes LP gas so useful. A large amount of fuel only occupies a small space and is therefore easy to store and transport. LP gas forms a combustible mixture with air when the proportion of gas is between 2 and 10 percent. When the gas changes from a liquid to a gaseous form, the volume increases by 250 times. For example, two liters (slightly less than one kilogram) of liquid LP gas produces 500 liters of gaseous fuel. In other words, the energy content is high. Compared with electricity, an LPG cylinder can produce several hundred kilowatts of power. LP gas can be stored in its container almost indefinitely without the gas breaking down.

## LP gas and the environment

- LP gas is non-toxic and does not contain hazardous additives.
- It does not contaminate air or water.

LP gas does not produce any hazardous combustion gases. Just carbon dioxide and water vapor. The gas does not contaminate water. It does not produce soot, it is not corrosive and it does not cause corrosion to iron or other metals. It does not contain lead or heavy metals and is non-toxic. In other words, LP gas is an environmentally friendly fuel.

The only additive is a strongly smelling substance that acts as a warning signal for leaking gas. Normally, LP gas has no smell.

## LP gas and handling

- Work in well-ventilated areas.
- Avoid placing the LP gas cylinder near source of heat.
- Ensure that the cylinder is stored upright during transport.

LP gas is clean and safe to use. You should however regularly check valves and connectors for leakage. Remember also that LP gas is about 1.5 times heavier than air. This means that good ventilation is important above and below areas where the gas is stored or used, where there is risk for leakage. Ventilation is also important to ensure effective combustion. Make sure that the cylinder is at ambient temperature when you begin working. If you are going to use the fuel at temperatures below zero Celsius, use propane instead as butane does not gasify at low temperatures.

## LP gas and fire

- Always extinguish LP gas fires with powder, never water.
- Move LP gas cylinders to a safe place if there is a fire in the vicinity.
- If possible, close the valve on the cylinder.

Steel cylinders are fitted with a safety valve that opens if the pressure increases too much. This can occur if there is a fire close to the cylinder. The valve stops the cylinders exploding. To guarantee the function of the safety valve, it is important that the LP gas cylinder is stored in a standing position. In addition, a closed valve stops unchecked gas flow if a hose should become damaged.

## LP gas and equipment

- Never allow an untrained person to use the equipment.
- Only use special LP gas parts
- Be extra careful with valves and connectors.

Never use other valves, burners or hoses than those designed for use with LP gas. IGT LP-gas hose conforms to the EN16436 standard. The hose consists of an internal rubber layer that is LP gas-proof, armoring an external rubber layer that can withstand air and aging. All equipment shown in this product catalog is manufactured of materials that withstand LP gas and is designed so that the risk for leakage is minimal.

## LP gas and checks

Ensures that you have the connect equipment for the job. Make sure that you have tightened all valves connectors. Regularly inspect the equipment and check that the system is seated.

Read the instructions for use and follow the safety advice. Use soapy water or a special liquid for detecting leakages on valves and joints to find any leaks. LP gas hoses should be checked very carefully and changed if you see any changes. Bend the hoses and look for cracks in the rubber. Hoses exposed to sunlight will age quicker than those used indoors.

## LP gas and storage

LP gas is not affected by long storage periods. Always disconnect equipment from the container. Store the cylinder in a well-ventilated area.

Avoiding storing LP gas cylinders in areas that are warm. Temperatures below zero Celsius are however, perfectly safe for storage. Ensure that the ventilation is good. In principal, LP gas can be stored indefinitely in its container without the quality being affected. Remember to remove all connectors before storing the equipment. To empty the system of gas, close the valve on the LP gas cylinder. Then close any valves on the rest of the equipment. In this way, you will avoid LP gas spillage when you open the system again.

## LP gas output from a cylinder

When LP gas turns from a liquid to a gas, heat is required which is taken from the liquid itself, from the container and from the surrounding air. LP gas and the bottle become cooler which reduces the pressure in the container, for larger burners, and especially during continuous use, a sufficient container size is necessary so that the burner can work at a constant power.

When using larger burners or burners with high gas consumption, ensure that cylinder size is large enough to deliver the required gas, without significant temperature drop. Table below shows an example of the maximum quantity of gas possible to use during one hour for burners requiring 2 bar pressure. Conditions for this example are the following gas – propane, cylinder size 11kg, continuous gas use during one hour, temperature of air and cylinder.

Temperature	+20 C	0 C
Full cylinder 11kg propane	3.8kg	1.6kg
Half cylinder 5.5kg propane	1.9kg	0.85kg

For large gas burners you need to have big gas cylinders with enough gas or several cylinders linked together.

## Temperature of the gas flame

Theoretically, LP gas has a maximum flame temperature of 1925 C. In practice, the temperature is not reached when heating an object, how much heat is dispersed, the ability of the burner to transfer heat, the size of the burner and how long the object is heated. Therefore, the choice of burner depends on the job to be carried out.

## Melting points of soldering metals

Tin solder	190-280 °C
Aluminum soft solders	380 °C
Aluminum hard solder	580 °C
Silver solder	610 °C
Phosphor-copper solder	720 °C
Bronze solder	860 °C

## Melting points of metals

Lead	327 °C
Zinc	419 °C
Aluminum	658 °C
Silver	961 °C
Gold	1063 °C
Copper	1084 °C

# PROPERTIES OF GASES

## Properties of gases

	Butane	Propane
Chemical symbol	C4H10	C3H8
Relative density of gas to air	Heavier than air	Heavier than air
(at 15 C, at atmospheric pressure)	2.0	1.5
Boiling point at atmospheric pressure	-2 C	-42 C
Pressure of gas at 0 C	Nil 4-5bar	
20 C	1-3bar	7-9bar
50 C	3-7bar	15-19bar
Ratio: Gas volume to liquid volume	238 279	
(at 15 C, at atmospheric pressure)		
Volume of gas to weight of liquid	420dm <sup>3</sup> /kg	540dm <sup>3</sup> /kg
(at 15 C, at atmospheric pressure)	6.6ft <sup>3</sup> /lb.	8.6ft <sup>3</sup> /lb.
Calorific value	49.5 MJ/kg	50.4 MJ/kg
(at 15 C, at atmospheric pressure)	21,200 Btu/lb.	21,500 Btu/lb.
	121.5 MJ/m <sup>3</sup>	93 MJ/m <sup>3</sup>
	3,200 Btu/ft <sup>3</sup>	2,500 Btu/ft <sup>3</sup>
	13.7 kWh/kg	14.0 kWh/kg
Air required for combustion:		
Ratio: Vol of to vol of gas	30	24
Minimum ignition temperature air	410 C	460 C
Relative flame speed (hydrogen=100)	16	16
Flame speed	0.36-0.40m/s	0.36-0.40m/s

## Recommended maximum offtakes from cylinders

When gas is drawn off a cylinder it causes the liquid to cool and the pressure to drop. If gas is taken too quickly the pressure drops below an acceptable level and in some cases water vapor in the air will freeze on the outside of the cylinder. If the cylinder will not give enough gas

For the applications fighter a larger cylinder must be used or cylinders must be coupled together using pigtailed and manifolds. Therefore maximum permitted off takes are laid down for given sizes as follows.

### Maximum offtake

Cylinder size

Butane	kW	Kg/h	Lb./h	Ft <sup>3</sup> /h	Dm <sup>3</sup> /h
4.5kg	5.73	0.418	0.92	6	175
14.5kg	9.5	0.696	1.53	10	280
propane					
4kg	7.3	0.528	1.16	10	280
13kg	14.6	1.054	2.32	20	570
19kg	18.3	1.319	2.90	25	710
47kg	32.9	2.373	5.22	45	1270

(These off takes can be exceeded for intermittent use of appliances)  
useful information sources



## LPGA

Excellent Web site-

[www.ipga.co.uk](http://www.ipga.co.uk)

Various codes of practice, especially

No.3 on fire with LPG

No. 4 on various propane appliances

No. 7 on storage of cylinders

No. 22 on piping systems

No. 24 on use of LPG cylinders

These publications are available from  
[UKLPG.COM](http://UKLPG.COM)

BS.5482 Pts.1, 2, 3 for Domestic Butane and Propane Gas  
Burning installations

HSE Guidance Note Cs6

The Storage and Use of LPG on

Construction Sites

Gas Safety (Installation and Use)

Regulations 1998, as amended

Both available from HMSO

## Some useful Conversions

1ft = 0.305m

1m = 3.28ft

1in = 25.4 mm

1mm = 0.039m

1dm<sup>3</sup> = 1 liter

1ft<sup>3</sup> = 28.30 dm<sup>3</sup> = 0.028m<sup>3</sup>

1m<sup>3</sup> = 1000 dm<sup>3</sup> = 35.31 ft<sup>3</sup>

1kW = 3412 btu/h = 1kj/s = 3.6 mj/h

1Btu/h = 0.000293 Kw

1lb = 0.454kg

1kg = 2.2lb

1 bar = 14.5 psi

1 psi = 0.0689 bar

1 in wg = 2.491 mbar

1 mbar = 0.401 in wg

## Data

All data in this catalogue are approximate.

Whilst every effort has been made to ensure the accuracy of the information in this catalogue we accept no responsibility for errors.

In line with our policy of continued improvement of our products we reserve the right to alter the specification of any item without notice.

# TORCH HANDLES

- Thumb adjustment  
Adaptable handles
- Double burner connection  
Seal: nitrile joint and  
Metal on metal cone
- 3/8" G connection thread
- Connection thread to burners  
M18 X 1 male or 3/8"



1048-6000

- Finger adjustment
- 3/8" G connection thread
- Connection thread to burners 3/8" G
- Extended inlet for Arm support



1048-3488

- Finger adjustment
- 3/8 G connection thread
- M14x1 connection thread



1048-3410



1048-3486  
Hobby Handle

Ref.3410 and 4703-4704 is a double-valve handle mainly for larger burners for roofing etc. It incorporates one man valve and one economizer valve enabling a gas-saving pilot flame. The trigger is used for instant shifting between pilot and man flame and for pulsing the main flame. The trigger can be locked to keep the main valve in the open position. Weight 380g, length 205mm, height 85mm, Connection for neck-tube or neck-tube burner BSP 3/8 RH.

Connection for hose nipple BSP 3/8" LH

Connection for hose nipple M14x1

# SWIRVEL ADAPTOR

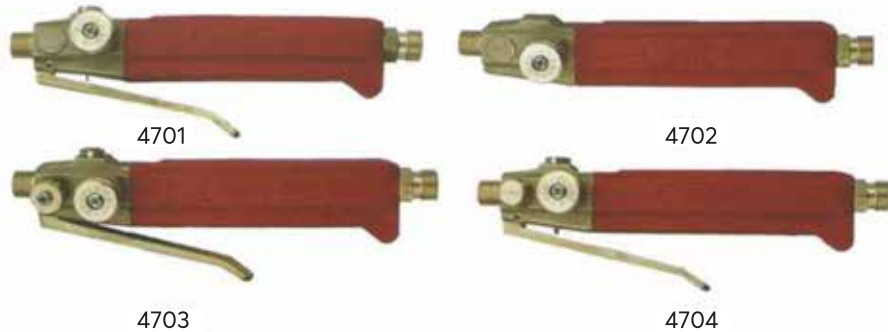

All handles – Intel 3/8" external thread (see info)- outlet M14x1 RH external thread				
CODE	TYPE	SHUT-OFF VALVE	VALVE FOR PRESETTING OF PILOT FLAME	QUICK OPENING TRIGGER VALVE
1048	4701	HAND-WHEEL	NO	YES
1048	4702	HAND-WHEEL	NO	NO
1048	4703	HAND-WHEEL	WITH SMALL HAND-WHEEL	YES
1048	4704	HAND-WHEEL	WITH SLOTTED SCREW	YES

Swirvel, for free rotating gas hose connection



CODE	TYPE	INTERNAL THREAD INTEL	EXTERNAL THREAD OUTLET (HANDLE)	DESIGN	MATERIAL
1029	0245	3/8" LH I	3/8" LH a	Straight line	Brass

## Soft soldering

Standard-flame burners and pin-point burners are designed for various sizes of soft soldering, gold and silver work, small heating applications etc.

Standard flame burner for soft soldering with fixed neck tube for direct connection to handles is a professional and powerful torch kit, ideal for soft soldering, brazing, melting, metalwork's, paint stripping and other heating jobs.



## Turbo Burners Soft Soldering Brass

Burner flame and temperature range

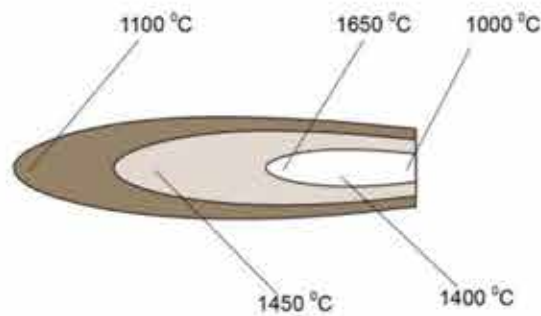

## Turbo Burner

CODE	TYPE	INTERNAL THREAD INLET	DIAMETER IN MM	WORKING PRESSURE IN BAR	CONSUMPTION 1.5 BAR IN KG/H	CAPACITY IN KW/H
1030	8316	M14x1	18	1.5-2.5	0.10	1.29
1030	8319	M14x1	19	1.5-2.5	0.14	1.80
1030	8322	M14x1	22	1.5-2.5	0.22	2.83

## Brazing and soft soldering

Cyclone burners are ideal for brazing and soft-soldering. The rotating flame provides the most efficient, even and all round transfer of heat to the pipe. For connection direct on to IGT handles. The gas pressure must be 2 bar. We recommend use of IGT regulator.

## Paint-stripping

Paint-stripping burner flat, wide, extremely windproof and powerful flame.

## Cable work-heat-shrinking

Soft-flame burners have windproof, soft flames with visible yellow tips. The flames are designed to heat the sleeves efficiently but still be soft enough not to overheat the shrink material.

## Sheet-metal work

Soldering iron in practical sturdy design. Supplied with windshield and burner designed to give excellent wind protection. Three different copper bits available. Supplied without copper bit.

## Point Burners Hard-and Softsoldering Brass

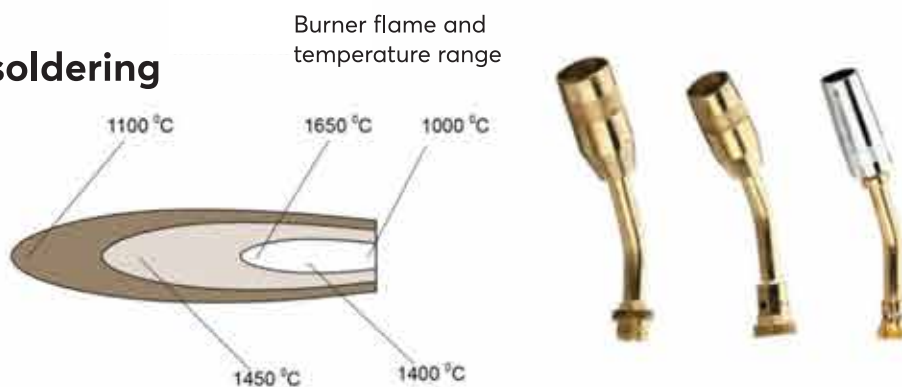

## Point burners

CODE	TYPE	INTERNAL THREAD INLET	DIAMETER IN MM	WORKING PRESSURE IN BAR	CONSUMPTION 1.5 BAR IN KG/H	CAPACITY IN KW/H
1030	8316	M14x1	18	1.5-2.5	0.03	0.39
1030	8319	M14x1	19	1.5-2.5	0.1	1.29
1030	8322	M14x1	22	1.5-2.5	0.20	2.57

# EXTENSION TUBES

## Extension Tubes



WORKING PRESSURE  
IN BAR

CODE	TYPE	INTERNAL THREAD INLET (HANDLE)	EXTERNAL THREAD OUTLET(BURNER)	LENGTH CA.IN MM	D.BETWEEN CENTRES	BURNER MAX.	SURFACR QUALITY
1020	3000	M14x1	M20x1	60	-	1	Nickeled
1020	3005	M14x1	M20x1	100	-	1	Nickeled
1020	3010	M14x1	M20x1	200	-	1	Nickeled
1020	3035	M14x1	M20x1	350	-	1	Nickeled
1020	3050	M14x1	M20x1	500	-	1	Nickeled
1020	3060	M14x1	M20x1	600	-	1	Nickeled
1020	3075	M14x1	M20x1	750	-	1	Nickeled
1020	3099	M14x1	M20x1	1000	-	1	Nickeled
1020	2422	M20x1	M20x1	550	115	2	Nickeled
1020	2444	M20x1	M20x1	550	140	4	Nickeled
1025	3000	3/8"	M20x1	60	-	1	Nickeled
1025	3005	3/8"	M20x1	100	-	1	Nickeled
1025	3010	3/8"	M20x1	200	-	1	Nickeled
1025	3035	3/8"	M20x1	350	-	1	Nickeled
1025	3050	3/8"	M20x1	500	-	1	Nickeled
1025	3060	3/8"	M20x1	600	-	1	Nickeled
1025	3075	3/8"	M20x1	750	-	1	Nickeled
1025	3099	3/8"	M20x1	1000	-	1	Nickeled

## Multiple Extensions



Pipe diameter 12x1,5 – compression strength 90bar						
COD	ETYPE	INTERNAL THREAD INLET (HANDLE)	EXTERNAL THREAD OUTLET(BURNER)	D.BETWEEN CENTRES	BURNER MAX.	SURFACR QUALITY
1020	2422	M20x1	M20x1	115	2	Nickelized
1020	2444	M20x1	M20x1	140	4	Nickelized



## Support

COD	ETYPE	DESCRIPTION
1020	0134	For assembly on to all extensions tubes, Mineral – galvanized sheet steel.

# BURNER HEADS

Burner flame and temperature range

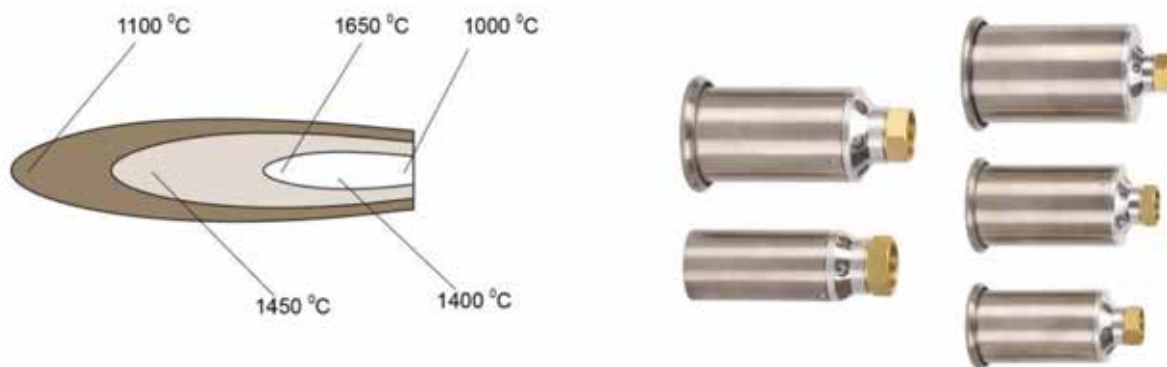

## Standard Windstable burner

Stainless Steel						
COD	ETYPE	INTERNAL THREAD INLET	DIAMETER IN MM	WORKING PRESSURE IN BAR	CONSUMPTION 1.5 BAR IN KG/H	CAPACITY IN KW/H
1030	3730	M20x1	30	0.5-4.0	1.4	20.59
1030	3740	M20x1	40	0.5-4.0	2.0	25.74
1030	3745	M20x1	45	0.5-4.0	2.4	30.89
1030	3750	M20x1	50	0.5-4.0	3.6	46.33
1030	3760	M20x1	60	0.5-4.0	8.0	102.96

Burner flame and temperature range



Burner flame and temperature range

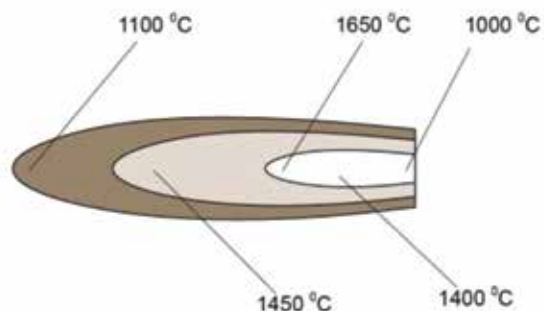

## Turbo burner

COD	ETYPE	INTERNAL THREAD INLET	DIAMETER IN MM	WORKING PRESSURE IN BAR	CONSUMPTION 1.5 BAR IN KG/H	CAPACITY IN KW/H
1030	8112	M14x1	12	1.5-2.5	0.04	0.51
1030	8116	M14x1	16	1.5-2.5	0.10	1.29
1030	8119	M14x1	19	1.5-2.5	0.14	1.80
1030	8122	M14x1	22	1.5-2.5	0.22	2.81

Burner flame and temperature range

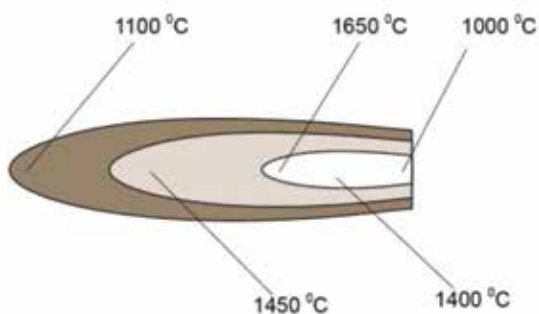

## Standard Point burner

COD	ETYPE	INTERNAL THREAD INLET	DIAMETER IN MM	WORKING PRESSURE IN BAR	CONSUMPTION 1.5 BAR IN KG/H	CAPACITY IN KW/H
1030	3119	M20x1	19	0.5-4.0	0.05	0.64
1030	3122	M20x1	22	0.5-4.0	0.15	1.93
1030	3128	M20x1	28	0.5-4.0	0.40	5.15
1030	3132	M20x1	32	0.5-4.0	0.70	b9.01

# BURNER HEADS

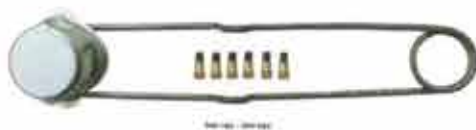

## Ignitor

COD	ETYPE	DESIGNATION	MATERIAL	LIFE EXPECTANCY IGNITER	MATERIAL
1029	5000	Flint Gas Lighter	Steel nickelized	Ca 2000	1
1029	5001	Flint Spares			10

# TITANIUM TORCHES

For long duration and best possible ergonomic use for all day use Titanium LOW WEIGHT extension tubes and burners head product range is recommended



Thread specification

A	M14x1
B	M18x1
C	3/8
D	M12x1

COD	ETYPE	Inlet	Ext thread	LENGTH	BURNER	TITANIUM
1028	3055	A B C	D	250	1	Titanium
1028	3055	A B C	D	250	1	Titanium
1028	3056	A B C	D	350	1	Titanium
1028	3057	A B C	D	500	1	Titanium
1028	3058	A B C	D	600	1	Titanium
1028	3059	A B C	Diameter D	Working pressure 750	Consumption 1	Titanium
1030	4751	D	50	0.5-4.0	3.6	Titanium
1030	4752	D	6	0.5-4.0	8.0	Titanium
1030	4753	D	70	0.5-4.0	10.0	Titanium



1030-4751

Ø50 mm



1030-4752

Ø60 mm



1030-4753

Ø70 mm

# TORCH SETS

## Roof Torch



## Weed Burner



## Example of set packed with hose, regulator, arm support





## IGT hoses and accessories

High pressure are approved to the new ISO3821 standard. IGT hoses are also extra frost-resistant and can be used in temperature down to -30 C

The hose is constructed with an inner layer of black gas-resistant rubber on which there is a layer of reinforcing weave to with-stand high pressure and an outer, orange colored layer to protect against external damage, sunlight and ozone.



Hose standard	Inside dia.(mm)	Length in meters	Connections		
En16436 PVC	6.3 8.0 10.0	100(roll)	G3/8",G1/4",5/8UNF G3/8",G1/4",5/8UNF G3/8",G1/2",5/8UNF		
ISO3821 RUBBER EN 16436	6.3 8.0 10.0 11.0	100(roll)	G3/8",G1/4",5/8UNF G3/8",G1/4",5/8UNF G1/2",5/8UNF		
CSA	6.3 8.0	100(roll)	G1/4",5/8UNF G1/4",5/8UNF		
AGA PVC	6.3 8.0	100(roll)	5/8UNF,1/8UNF 5/8UNF,1/8UNF		
Hose Clips					
Materials	Carbon Steel	Stainless Steel	Stainless Steel		
Inside Dia	8-18mm 12-20mm	8-18mm 12-20mm	8-18mm		
Hose nipples					
No.	A900-109	A900-061	A900-084	A900-080	A900-055
Inside Dia.	8mm	6.3MM	10MM	8MM,11MM	11MM
Thread	G1/4"	G3/8"	G1/4"	G1/4"	G1/2

# USA GAS TORCHES

1050-2000



Inlet G3/8"  
500,000BTUs

1050-2001



Inlet G3/8"  
500,000BTUs

1050-2002



Inlet G3/8"  
500,000BTUs

1050-2003



Inlet G3/8"  
500,000BTUs

1050-2004



Inlet G3/8"

500,000BTUs

1050-2005



Inlet G3/8"

500,000BTUs

1050-2005



500,000BTUs

# HEATING SHRINK TORCH



## 1070-1000

Shrink torch for polyethylene covers and sheets

Equipment	SWT-02
Energy source	Propane/f3p
Qn	221789 BTU
Operating pressure(bar)	21.7 to 50.7 psi
Adjustable power(from 21.7psi to 50.7 psi)(kw)	From 126249 to 225201 BTU
Flow rate (kg/hr)	From 5.73 to 10.58 lb/h
Air consumption(m3/hr)	From 62.78 cu yd/ph to 94.14 cu yd/ph(approx.)
Weight(kg)	2.64 lb
Safety device	"Dead man's handle" with protection
Excess flow	Excess flow safety device on regulator gauge
Suitable accessories	Thermal protection (original)"air" clip
Noise level(dBA)	85-88



# HIGH PRESSURE REGULATORS B100/B235/B300

## Snap on compact HP regulator B100

### Applications:

Used in conjunction with a cylinder valve to reduce cylinder pressure to a 0-2 bar outlet pressure required for operation of torches, burner and furnaces for commercial and industrial applications.

### Specifications:

Inlet options: 20/21/22/27mm

Outlet options: 8mm/11mm

Rated capacity 8 kg/h

Outlet pressure: 0-2bar (adjustable)

Body and cover: Die cast zinc alloy

Diaphragm; NBR



## Jumbo HP regulator B235is

### Applications:

Used in conjunction with a cylinder valve to reduce cylinder pressure to a 0-2 bar outlet pressure required for operation of torches, burner and furnaces for commercial and industrial applications.

### Specifications:

Inlet size: 35mm

Outlet options: 8mm/10/11mm, 3/8" BSP or G1/2" thread connector

Rated capacity 4 kg/h

Outlet pressure; 0-2bar (Adjustable)

Diaphragm: NBR



B235isf



B235is

# HIGH PRESSURE REGULATORS

## B100/B235/B300

### Hand Wheel HP regulators-B300/B310

#### Applications:

Used in conjunction with a cylinder valve to reduce cylinder pressure to a 0-2 bar outlet pressure required for operations of torches, burner and furnaces for commercial and industrial applications

#### Specifications:

Inlet Numerous possible types of inlet  
 Outlet connection : 3/8" BSP thread connector  
 Outlet pressure options: 1.5/2.5/4bar  
 Nut material options: Steel or Brass  
 Body and cover : Die cast zinc alloy  
 Diaphragm: NBR



### Excess Flow Valve - A900

#### Specifications:

Specifications;  
 Inlet Female 3/8" LH  
 Outlet Male 3/8 " LH  
 Inlet press: 1.5 – 4 bar  
 Cut off rate: 6 – 8.5 kg/hr  
 DVGW approved.



B310 Adjustable

### A900 - 129

Pol with excess flow valve  
 Hose: EN16436 class3 with heavy sleeves

S006 10m length	3/8" -3/8" nut both ends
S006 5m length	3/8" -3/8"swavd nut
S006 2m length	



B300-033



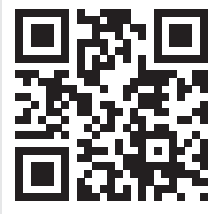

[WWW.IGT-LPG.COM](http://WWW.IGT-LPG.COM)



**Integrated Gas  
Technologies**

**Denmark**

Version 1.0.

**HEAD OFFICE IN DENMARK  
INTEGRATED GAS TECHNOLOGIES**  
Gydevang 39-41 DK-3450 Allerød Denmark  
Tel: 0045-4576 9921 | Fax: 0045-4576 9821  
E: sales@igt-lpg.com | W: www.igt-lpg.com

**FACTORY IN CHINA  
NINGBO SHUAI XIAN REGULATOR CO. LTD**  
No 566, Jinshan Road, Zone C, Investment center  
Jiangbei District, Ningbo Zhejiang, China  
E: sales@igt-lpg.com | W: www.igt-lpg.com

**FACTORY IN INDIA  
INTEGRATED GAS CONTROLS TECHNOLOGIES PVT. LTD**  
Survey No.784, 14-59/3A,  
Medchal Village, Near Ravalkole  
"X" Road, Medchal Mandal  
& Medchal - Makajgir District.  
E: info@igt-lpg.in | W: www.igt-lpg.in

**40+**  
MILLION  
SAFE FAMILIES

**120+**  
COUNTRIES

**400+**  
PRODUCTS

**25+**  
CERTIFICATES